

The ROSE 80 CW Transceiver

(Part 1 of 3)

Build a 5 watt, 80 meter QRP CW Transceiver!!!

(Designed by N1HFX)

A great deal of interest has been generated by my previous design articles, so I decided to go to work on a full blown transceiver design. After several months of work, the ROSE-80 transceiver was born. This transceiver is similar to other designs but contains some unique differences. This design boasts the following features:

1. Full 5 watt output using a power MOSFET final that is resistant to high SWR and thermal runaway. This final is very efficient and runs much cooler than traditional bipolar designs.
2. Highly sensitive and selective superhetrodyne receiver with plenty of audio to drive a speaker. About 100 Khz of tuning range is provided through a varactor diode along with a switchable RIT control.
3. Full break-in keying with a unique T/R switching system.

Work is continuing on a printed circuit board and this circuit is expected to be available as a complete kit including all electronic parts, PCB and instruction manual at a future date. My prototype was built on Radio Shack universal boards.

This month, we'll begin by building the VFO. The VFO uses a JFET for stability and a varactor diode to provide the necessary tuning. Many other JFET's such as the 2N3819 or 2N4416 can be substituted for Q1 and Q2 but pay attention to the pinouts because the 2N3819 has a different pinout than the MPF102. Capacitors C2 and C4 are polystyrene to minimize drift and C1 is an NPO type.

The wire size is not critical for L1 but #26 wire works well and is readily available. First wind 21 turns on a T50-6 (yellow) toroid and connect the tap. Wind the last 7 turns and connect the end to the ground in the circuit. I highly recommend the use of a sharp knife to scrape the insulation off the wires. The use of a match leaves residue on the wire which must be scraped off anyway prior to soldering.

Trimmer capacitor C3 is a 5 millimeter, 9 to 50 picofarad type. I used Mouser #24AA024 but other less expensive types will work well. Adjust C3 for the desired tuning range. The VFO should be in the range of 4.3 to 4.4Mhz.

Varactor diode D2 is a MV2109 but other types such as the MV2108 will work well. This diode is somewhat difficult to obtain but other rectifier diodes such as a 1N4001 or 1N4004 will work fine. Experiments with using the base and collector of general purpose transistors also worked well. You will need to try several diodes or transistors of the same type to get the desired capacitance swing. Remember, rectifier diodes and transistors were not manufactured for this purpose so they don't all have the same capacitance swing. Varactor diodes cost more because they are manufactured to have a specific capacitance swing. However, it is a well known fact that almost all reversed biased diodes will have a small degree of capacitance which decreases as the applied voltage increases. As with all varactor tuning systems, there will be a substantial amount of drift during the first 3 minutes of operation. Keep in mind that diodes are very temperature sensitive and best results will be obtained when the completed project is placed in an enclosure.

Potentiometer R3 is used for the main tuning and potentiometer R5 is the RIT control which gives about a 5Khz swing. For testing purposes, temporarily connect a 10k to 100K resistor to the On lead of S2 to ground to allow the RIT to work properly. This resistor can be removed after the circuit is completed and tested. IC1 is a LM339 open collector output quad comparator which is available at any Radio Shack. This IC provides the necessary switching off of the RIT control during transmit.

VR1 is a 5 volt low power regulator pushed up to 8 volts by resistor R12 and R13. The 78L05 was chosen because of its low cost and availability. A 7805 could be substituted if desired. A 78L08 could also be substituted but R12 and R13 must be eliminated. Connect a lead to ground in place of R13 for the 78L08 IC.

That's all for now folks!!!. Next month we'll build the receiver circuit.

DE N1HFX

Part Sources:

Mouser Electronics
958 North Main Street
Mansfield, CT 76063-4827
1-800-346-6873
<http://www.mouser.com>

JDR Microdevices
1850 South 10th Street
San Jose, CA 95112-4108
1-800-535-5000
<http://www.jdr.com>

Dan's Small Parts & Kits
Box 3634
Missoula, Montana 59806-3634
1-406-258-2782
<http://www.fix.net/dans.html>

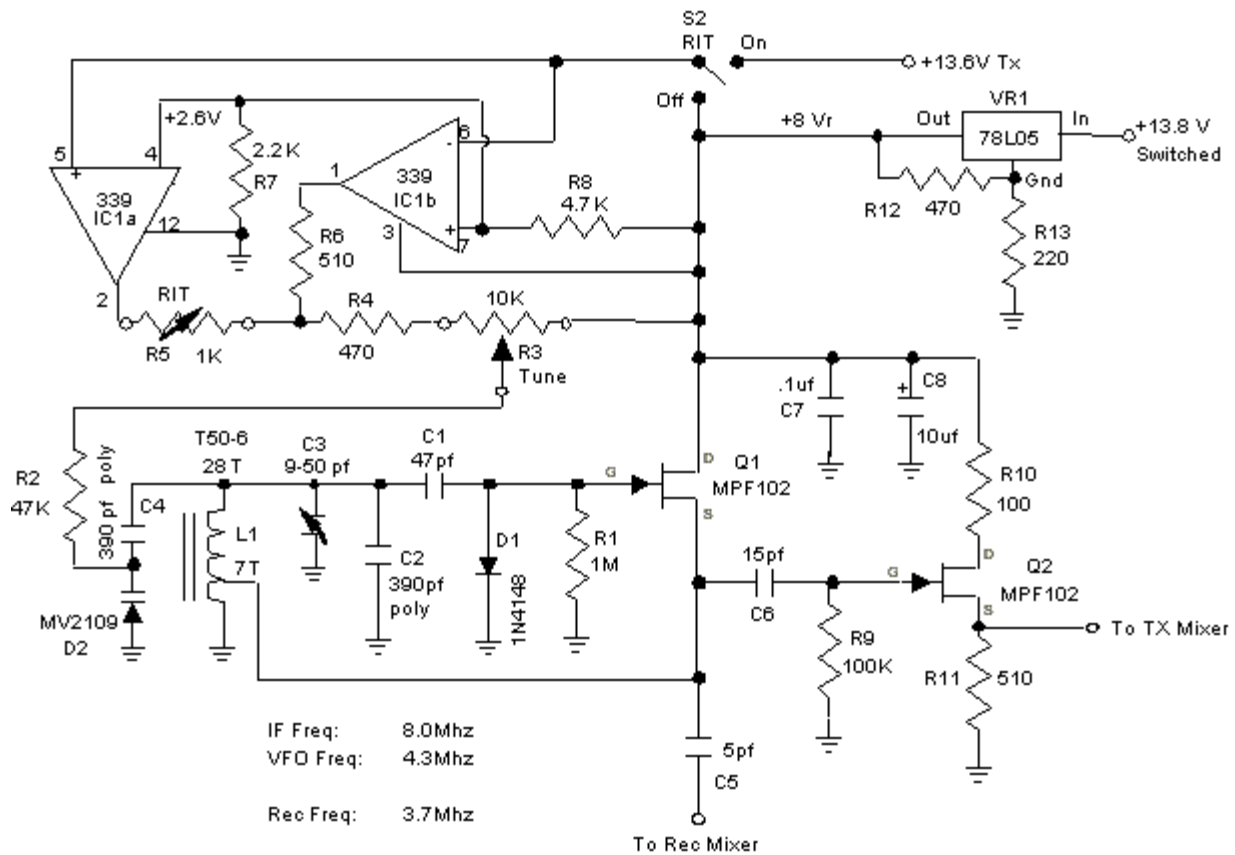

Rose-80 Transceiver VFO Schematic

(Part 2 of 3)

Build a 5 watt, 80 meter QRP CW Transceiver!!! (Designed by N1HFX)

Last month we started off building the VFO for the Rose 80 transceiver. This month we are going to build the superhetrodyne receiver circuit.

The input signal enters the circuit through transformer T1 and C9 resonates with the secondary winding to form the receiver front end. C9 should be adjusted for maximum signal strength. This 3.7Mhz signal is fed into the NE602 mixer along with the 4.3Mhz VFO and is converted up to 8Mhz.. Transformer T2 and C12 matches the impedance of the NE602 output to the 50 ohm input of the 8Mhz crystal filter. Y1 through Y4 form the 8 MHz crystal filter which provides excellent selectivity for the receiver. L2 and C21 matches the 50 ohm output of the crystal filter to the final NE602 mixer. An 8Mhz crystal is fed into the last mixer resulting in the audio output. Transistor Q3 is a JFET used to partially mute the receiver during transmit to form the transmit side tone. Because there is no IF amplifier in this circuit, transistor Q4 is used to boost the audio level so that adequate drive is supplied to IC4. Diodes D4 and D5 are germanium clipping diodes to prevent loud signals from blasting us out. Germanium diodes were selected over silicon because they clip at .3 volts instead of .7 volts for silicon. Potentiometer R22 is the volume control and IC4 is the audio amplifier providing plenty of speaker or headphone volume.

The wire size is not critical for L2, T1 and T2 but #26 wire works well and is readily available. Trimmer capacitors C9 and C25 are Mouser #24AA024. Capacitor C25 should be adjusted for best reception in the upper sideband. The 8Mhz crystals Y1 through Y5 are Mouser #520-HCA800-20. Crystals Y1 through Y4 should be matched within 20 Hertz for best filter performance.

It is perfectly OK to substitute the less expensive NE612 for the NE602 since they have the same pin out and provide equal performance at HF frequencies. JFET Transistor Q3 can be substituted with a 2N3819 or 2N4416. Transistor Q4 should not be substituted. However, it is readily available at low cost.

The NE602's receive their 8 volts from regulator VR1 which is listed in the VFO schematic. An IF amplifier was not used in this circuit because the NE602's have a lot of conversion gain. Experience has shown that an additional IF amplifier at these frequencies does little more than improve audio levels and can cause overloading of the final mixer.

That's all for now. Next month we'll finish it all up with the transmitter circuit.

DE N1HFX

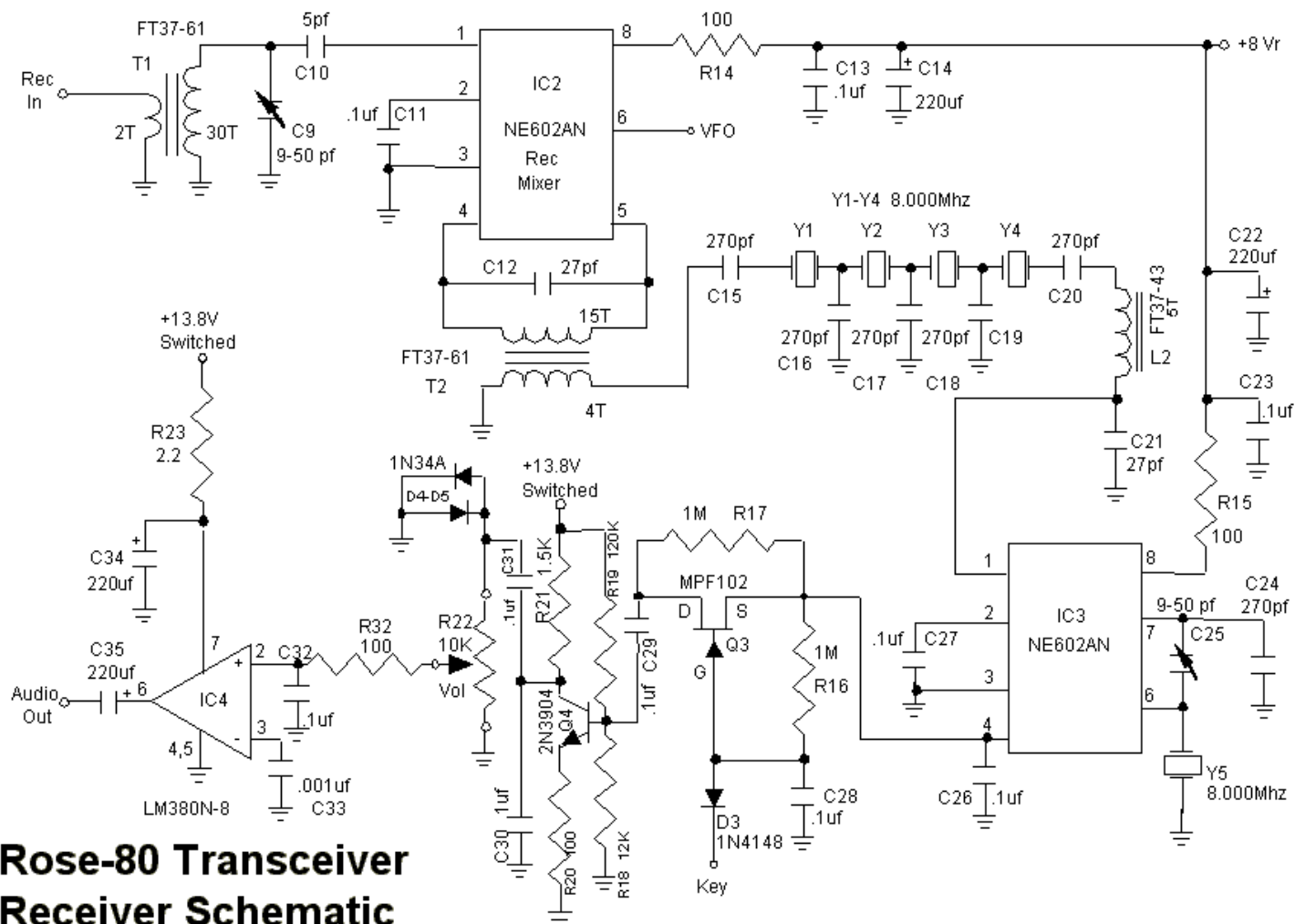

Rose-80 Transceiver Receiver Schematic

The ROSE 80 CW Transceiver (Part 3 of 3)

Build a 5 watt, 80 meter QRP CW Transceiver!!! (Designed by N1HFX)

Now that we have a working receiver and VFO, its time to build the transmitter and the TR switching circuit.

The 4.3Mhz VFO is now applied to the transmit mixer, IC5, and is mixed with the 8 MHz crystal oscillator to give 3.7Mhz. Capacitor C40 should be adjusted so that the desired (upper) sidetone is heard in the receiver while transmitting. Transformers T3 and T5 (Mouser 421F123) are used to filter unwanted harmonics and spurs. T3 should be adjusted for maximum output at the higher end of the band while T5 should be adjusted at the lower end of the band. Resistor R37 controls the input impedance of the gate along with the output power and should be adjusted no higher than 5 watts out. The IRF510 is capable of higher power but at the risk of instability. Transformer T4 uses a Bifilar winding to match the output impedance. Capacitors C55 and C56 (silver mica) are needed to offset excess inductance in the drain circuit and enhance stability. R39 and C54 form a small amount of negative feed back further enhancing stability. The 15 volt zener diode D6 protects the gate of Q8 from excessive voltage. Resistor R38 prevents oscillations which sometimes occur with the use of zener diodes on the gates of power MOSFET transistors.

The T/R circuit uses a pair of 1N4001 diodes as switching diodes. At 80 meters it simply isn't necessary to use expensive low noise pin diodes because almost all of the noise encountered is atmospheric. The receiver input is connected to C59.

This T/R circuit allows a very small amount of RF to pass during transmit to provide the needed sidetone. Capacitors C60 through C62 are part of the low pass filter and are Silver Mica types.

Final transistor Q8 is fairly resistant to periods of high SWR and of course thermal runaway is not a problem for power MOSFET's. The operator does not need to worry about occasional key downs with out an antenna connected.

That's it for the ROSE 80 transceiver construction. I hope to work you soon with your ROSE 80 rig!!!

DE N1HFX

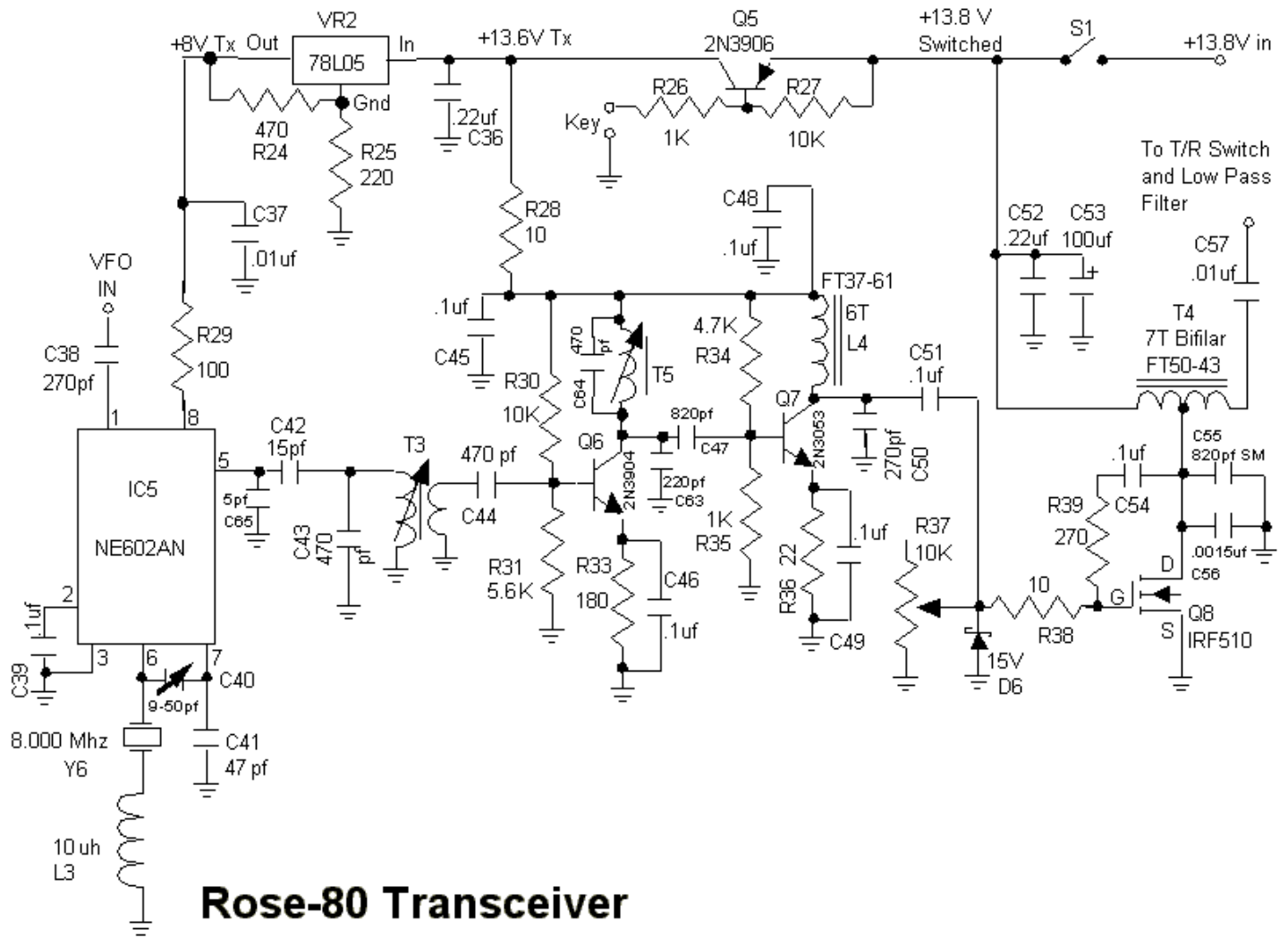

**Rose-80 Transceiver
Transmitter Schematic**

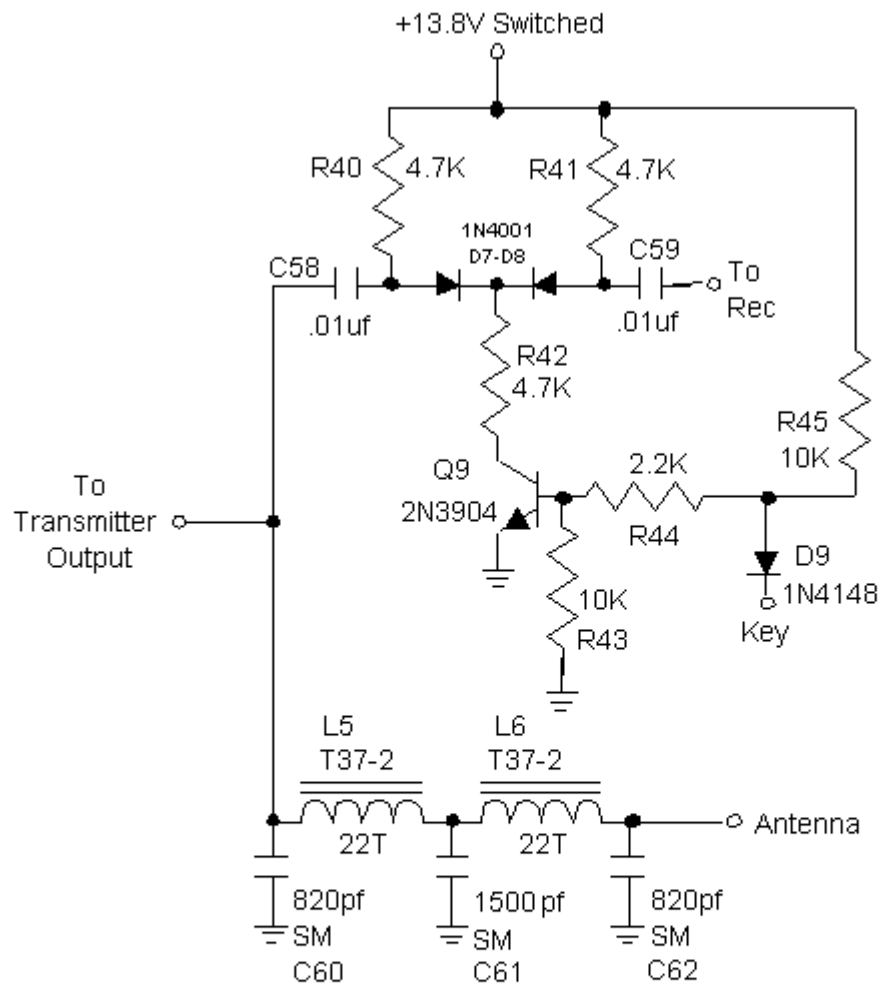

Rose-80 Transceiver T/R Switch and Low Pass Filter Schematic

Parts List

Reference	Description
C1,C41	47pf ceramic disk capacitor, NPO
C12,C21	27pf ceramic disk capacitor 5%
C14,C22,C34, C35	220uf electrolytic capacitor, 25V or greater
C15,C16,C17, C18,C20,C24, C38,C50	270pf ceramic disk capacitor, 100V or greater
C19	Not Used
C2,C4	390pf polystyrene capacitor
C3,C9,C25, C40	9-50pf trimmer capacitor (Mouser 24AA024)

C33	.001uf ceramic disk capacitor
C36,C52	.22uf ceramic disk capacitor
C37,C57,C58, C59	.01uf ceramic disk capacitor
C43,C44,C64	470pf ceramic disk capacitor 5%
C47	820pf ceramic disk capacitor, 25V or greater
C5,C10,C65	5pf ceramic disk capacitor
C53	100uf electrolytic capacitor, 25V or greater
C55,C60,C62	820pf silver mica capacitor, 100V or greater
C56,C61	1500pf silver mica capacitor, 100V or greater
C6,C42	15pf ceramic disk capacitor
C63	220pf ceramic disk capacitor
C7,C11,C13, C23,C26,C27, C28,C29,C30, C31,C32,C39, C45,C46,C48, C49,C51,C54	.1uf ceramic disk capacitor, 25V or greater
C8	10uf electrolytic capacitor, 25V or greater
D1,D3,D9	1N4148 switching diode
D2	MV2108 or MVAM109 varactor diode
D4,D5	1N34A germanium diode
D6	1N5245B 15V zener diode
D7,D8	1N4001 rectifier diode
IC1	LM339 quad comparator IC
IC2,IC3,IC5	NE602AN or NE612AN doubly balanced mixer/oscillator IC
IC4	LM380N-8 audio amplifier IC
L1	T50-6 toroid, 28 turns #26 wire tapped at 7 turns from ground
L2	FT37-43 toroid, 5 turns #26 wire, 10.5uh
L3	10uh molded choke
L4	FT37-61 toroid, 6 turns #26 wire, 2uh
L5,L6	T37-2 toroid, 22 turns #26 wire, 1.94uh
Q1,Q2,Q3	MPF102 JFET transistor

Q4,Q6,Q9	2N3904 NPN transistor
Q5	2N3906 PNP transistor
Q7	2N3053 NPN transistor
Q8	IRF510 power MOSFET transistor.
R1,R16,R17	1 Meg ohm resistor, 1/4 watt, 5%
R10,R14,R15, R20,R29,R32	100 ohm resistor, 1/4 watt, 5%
R13,R25	220 ohm resistor, 1/4 watt, 5%
R18	12K ohm resistor, 1/4 watt, 5%
R19	120K ohm resistor, 1/4 watt, 5%
R2	47K ohm resistor, 1/4 watt, 5%
R21	1.5K ohm resistor, 1/4 watt, 5%
R22	10K potentiometer with switch, 6.4mm (1/4") shaft, 1/2 watt
R23	2.2 ohm resistor, 1/4 watt, 5%
R26,R35	1K ohm resistor, 1/4 watt, 5%
R27,R30,R43, R45	10K ohm resistor, 1/4 watt, 5%
R28,R38	10 ohm resistor, 1/4 watt, 5%
R3	10K potentiometer, 6.4mm (1/4") shaft, 1/2 watt
R31	5.6K ohm resistor, 1/4 watt, 5%
R33	180 ohm resistor, 1/4 watt, 5%
R36	22 ohm resistor, 1/4 watt, 5%
R37	10K or 5K PCB cermet potentiometer, 1/2 watt
R39	270 ohm resistor, 1/4 watt, 5%
R4,R12,R24	470 ohm resistor, 1/4 watt, 5%
R5	1K potentiometer, 6.4mm (1/4") shaft, 1/2 watt
R6,R11	510 ohm resistor, 1/4 watt, 5%
R7,R44	2.2K ohm resistor, 1/4 watt, 5%
R8,R34,R40, R41,R42	4.7K ohm resistor, 1/4 watt, 5%
R9	100K ohm resistor, 1/4 watt, 5%
S1	SPST switch, included as part of R22
S2	SPDT switch for RIT control
T1	FT37-61 toroid, 2 turns #26 wire primary, 30 turns #26 wire secondary
T2	FT37-61 toroid, 15 turns #26 wire primary, 4 turns #26 wire secondary

T3,T5	10.7 Mhz IF transformer, Mouser 42IF123. (Secondary unused for T5)
T4	FT50-43 toroid, 7 bifilar turns #26 wire
VR1,VR2	78L05 5V voltage regulator IC
Y1,Y2,Y3,Y4, Y5,Y6	8.000 MHz crystal (matched set) Mouser 520-HCA800-20